

Auslaufventil PN 10 mit Selbstschluss

Rotguss
ohne Auslaufrohr

- Flanschbohrungen nach DIN PN 10

Drain Valve PN 16 Self-closing

gunmetal
without drainpipe

- flange drilling acc. to DIN PN 10

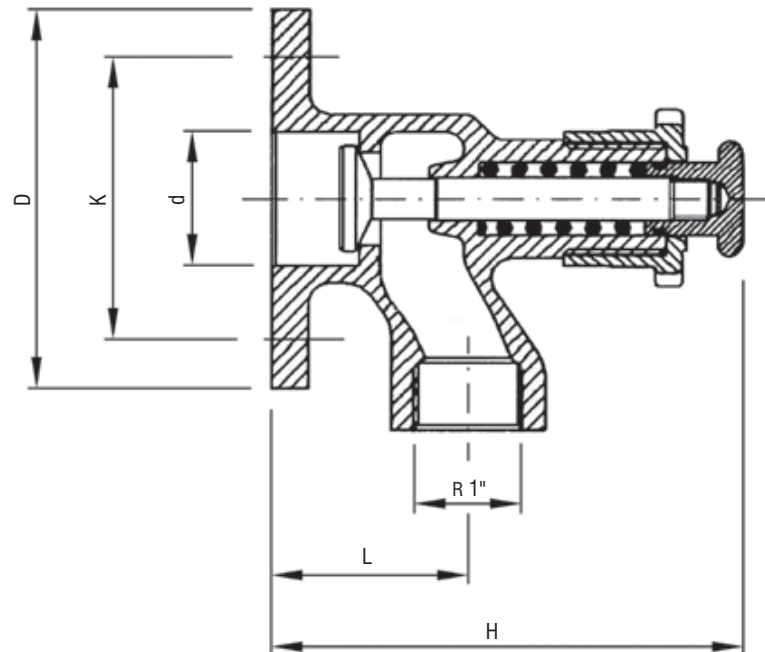

AW-Nr. AW no.	Pos. item	Bezeichnung denomination	Werkstoff material	nach DIN EN acc. to DIN EN	Werkstoff-Nr. material no.
249	1	Gehäuse / body	Rotguss / gunmetal	CuSn5Zn5Pb5-C	CC491K
	2	Spindel / stem	Sondermessing / special brass	CuZn35Ni3Mn2AlPb	CW710R
	3	Druckfeder / pressure spring	Bronze / bronze	CuSn6	CW452K
	4	Reguliergriff / regulation lever	Rotguss / gunmetal	CuSn5Zn5Pb5-C	CC491K
	5	O-Ring / O-ring	NBR		
	6	Druckknopf / push button	Messing / brass	CuZn39Pb2	CW612N

DN	ØD	L	H	Ød	Økx	nx	Ød ₁	≈ kg
15	95	60	145	40	65	4	M12	-
20	105	60	145	40	75	4	M14	2,2
25	115	60	145	40	85	4	M14	2,4

Verwendung

Geeignet für Wasser, Öl, Treibstoff und andere neutrale, nicht aggressive Medien.

Application

Suitable for water, oil, fuel oil and other neutral, non aggressive media.

max. Temperatur / max. temperature

80°C