

Grobfilter PN 4

Rotguss, Eckform

- Flanschbohrungen nach DIN PN 10
- Gehäusemaße nach DIN 87151
- Verwendung: Vorwiegend in Saug- und Druckleitungen, z.B. der Kühlwasser und Lenzanlagen
- Sieb aus nichtrostendem Stahl mit 8 mm Quadratlochung oder 5 mm Rundlochung
andere Werkstoffe und Lochungen auf Anfrage

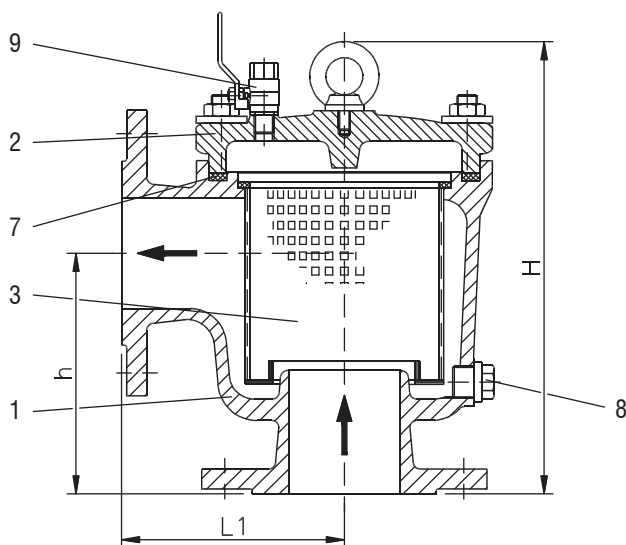

Mud Box PN 4

gunmetal, angle pattern

- flange drilling acc. to DIN PN 10
- body dimensions acc. to DIN 87151
- application: mainly for use in suction and discharge pipelines, e.g. cooling water- and bilge systems
- screen of stainless steel with 8 mm square holes or 5 mm round holes
others on request



Abb. / figure: DN 80

Pos. item	Bezeichnung denomination	AW 601.0		Pos. item	Bezeichnung denomination	AW 601.0	
1	Gehäuse / body	CuSn5Zn5Pb5-C	CC491K	7	Dichtung / gasket	NBR	
2	Deckel / cover	CuSn5Zn5Pb5-C	CC491K	8	Entleerungsschraube / drain bolt	CuZn39Pb2	CW612N
3	Sieb / screen	X5CrNi18-10	1.4301	9	Entlüftungskugelhahn / vent ball valve (optional)	CuZn39Pb2 galv.	CW612N
4	Stiftschraube / stud bolt	5.8					
5	Mutter / nut	CuZn39Pb2	CW612N				
6	Ringschraube / ring bolt	C15E	1.1141				

DN	PN	L ₁	h	H	øb	øD	øk	n	ød	Normalleistung m ³ /h* normal capacity m ³ /h*	≈ kg
32	4,0	125	125	238	242	140	100	4	18	6,8	17,5
40	4,0	125	125	238	242	150	110	4	18	6,8	17,5
50	4,0	135	135	258	268	165	125	4	18	10,6	19,5
65	4,0	150	150	288	296	185	145	4	18	18,0	29,0
80	4,0	175	175	318	326	200	160	8	18	30,0	34,5
100	4,0	195	195	369	394	220	180	8	18	42,2	48,5
125	4,0	220	220	407	442	250	210	8	18	66,2	69,0
150	4,0	270	270	489	512	285	240	8	22	95,4	96,5

*:1,5 m/s

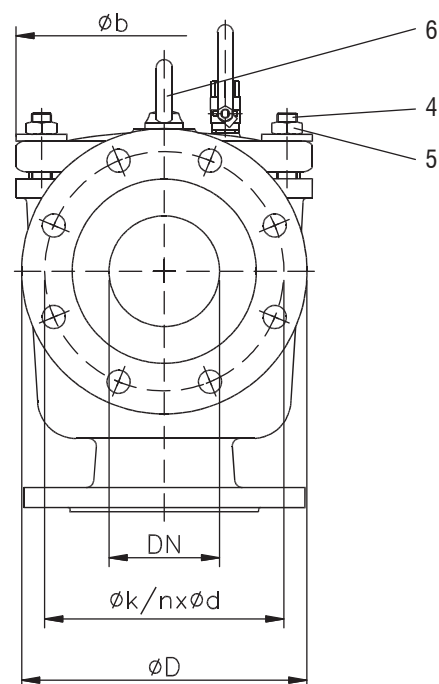
Grobfilter PN 2,5

Rotguss, Eckform

- Flanschbohrungen nach DIN PN 10
- Verwendung: Vorwiegend in Saug- und Druckleitungen, z.B. der Kühlwasser und Lenzanlagen
- Sieb aus nichtrostendem Stahl mit 8 mm Quadratlochung oder 5 mm Rundlochung
andere Werkstoffe und Lochungen auf Anfrage

Mud Box PN 2,5

gunmetal, angle pattern

- flange drilling acc. to DIN PN 10
- application: mainly for use in suction and discharge pipelines, e.g. cooling water- and bilge systems
- screen of stainless steel with 8 mm square holes or 5 mm round holes
others on request

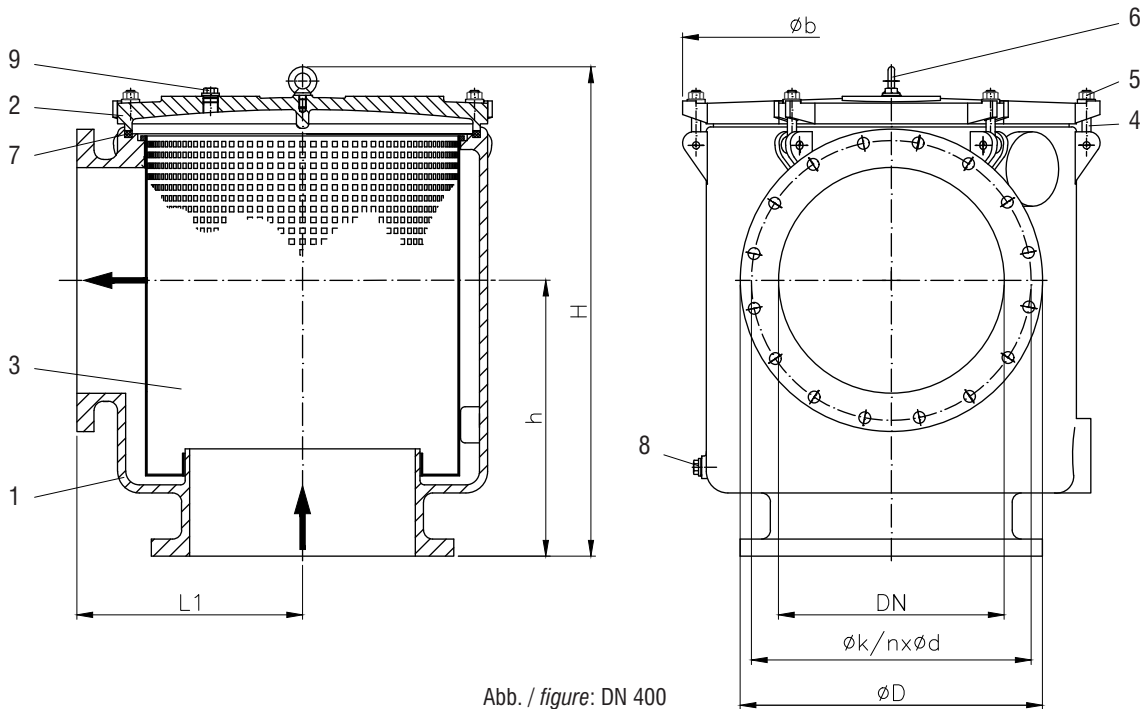

Abb. / figure: DN 400

Pos. / item	Bezeichnung / denomination	AW 601.0		Pos. / item	Bezeichnung / denomination	AW 601.0	
1	Gehäuse / body	CuSn5Zn5Pb5-C	CC491K	7	Dichtung / gasket	NBR	
2	Deckel / cover	CuSn5Zn5Pb5-C	CC491K	8	Entleerungsschraube / drain bolt	CuZn39Pb2	CW612N
3	Sieb / screen	X5CrNi18-10	1.4301	9	Entlüftungskugelhahn / vent ball valve (optional)	CuZn39Pb2 galv.	CW612N
4	Augenschraube / eye bolt	5.8					
5	Mutter / nut	CuZn39Pb2	CW612N				
6	Ringschraube / ring bolt	C15E	1.1141				

DN	PN	L1	h	H	øb	øD	øk	n	ød	Normalleistung m ³ /h* normal capacity m ³ /h*	≈kg
200	2,5	300	300	532	560	340	295	8	22	170,0	158,0
250	2,5	300	425	716	500	395	350	12	22	265,0	198,0
300	2,5	310	400	700	500	445	400	12	22	380,0	202,0
350	2,5	340	440	800	560	505	460	16	22	520,0	263,0
400	2,5	450	520	895	735	565	515	16	26	650,0	537,0

*:1,5 m/s