

## Grobfilter PN 4

### Sphäroguss, Durchgangsform

- Flanschbohrungen nach DIN PN 10
- Gehäusemaße nach DIN 87151
- Verwendung: Vorwiegend in Saug- und Druckleitungen, z.B. der Kühlwasser und Lenzanlagen
- Sieb aus nichtrostendem Stahl mit 8 mm Quadratlochung oder 5 mm Rundlochung  
andere Werkstoffe und Lochungen auf Anfrage



Abb. / figure: DN 80

## Mud Box PN 4

### nodular cast iron, straight pattern

- flange drilling acc. to DIN PN 10
- body dimensions acc. to DIN 87151
- application: mainly for use in suction and discharge pipelines, e.g. cooling water- and bilge systems
- screen of stainless steel with 8 mm square holes or 5 mm round holes  
others on request

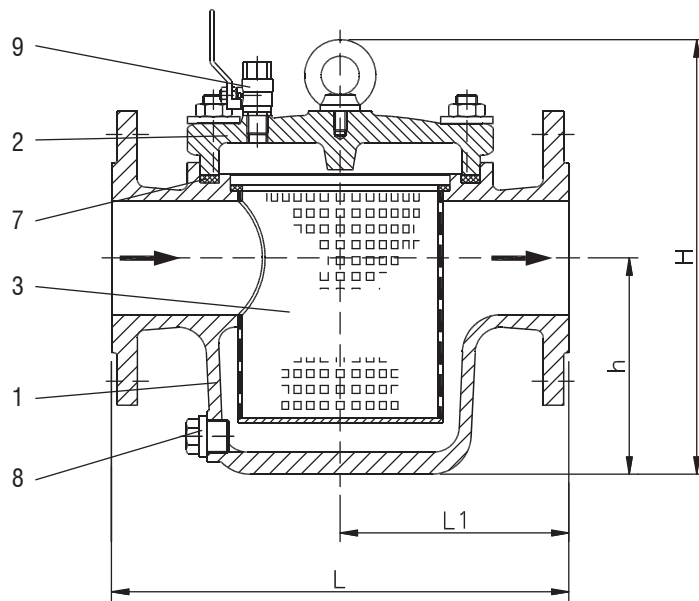
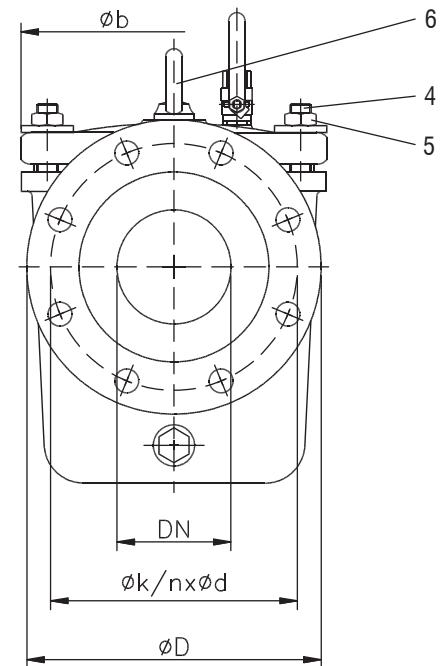

Pos. item	Bezeichnung denomination	AW 608.0		Pos. item	Bezeichnung denomination	AW 608.0	
1	Gehäuse / body	EN-GJS-400-15	EN-JS1030	7	Dichtung / gasket	NBR	
2	Deckel / cover	EN-GJS-400-15	EN-JS1030	8	Entleerungsschraube / drain bolt	CuZn39Pb2	CW612N
3	Sieb / screen	X5CrNi18-10	1.4301	9	Entlüftungskugelhahn / vent ball valve (optional)	CuZn39Pb2 galv.	CW612N
4	Stiftschraube / stud bolt	5.8					
5	Mutter / nut	CuZn39Pb2	CW612N				
6	Ringschraube / ring bolt	C15E	1.1141				

DN	PN	L	L <sub>1</sub>	h	H	øb	øD	øk	n	ød	Normalleistung m <sup>3</sup> /h* normal capacity m <sup>3</sup> /h*	≈kg
32	4,0	200	100	95	202	202	150	100	4	18	6,8	12,0
40	4,0	200	100	95	202	202	150	110	4	18	6,8	12,0
50	4,0	230	115	106	224	242	165	125	4	18	10,6	16,5
65	4,0	290	145	134	263	268	185	145	4	18	18,0	21,5
80	4,0	310	155	156	299	296	200	160	8	18	30,0	29,0
100	4,0	350	175	185	339	326	220	180	8	18	42,2	37,0
125	4,0	400	200	229	416	394	250	210	8	18	66,2	57,0
150	4,0	480	240	268	468	442	285	240	8	22	95,4	77,0

\*:1,5 m/s

## Grobfilter PN 2,5

### Sphäroguss, Durchgangsform

- Flanschbohrungen nach DIN PN 10
- Verwendung: Vorwiegend in Saug- und Druckleitungen, z.B. der Kühlwasser und Lenzanlagen
- Sieb aus nichtrostendem Stahl mit 8 mm Quadratlochung oder 5 mm Rundlochung  
andere Werkstoffe und Lochungen auf Anfrage

## Mud Box PN 2,5

### nodular cast iron, straight pattern

- flange drilling acc. to DIN PN 10
- application: mainly for use in suction and discharge pipelines, e.g. cooling water- and bilge systems
- screen of stainless steel with 8 mm square holes or 5 mm round holes  
others on request

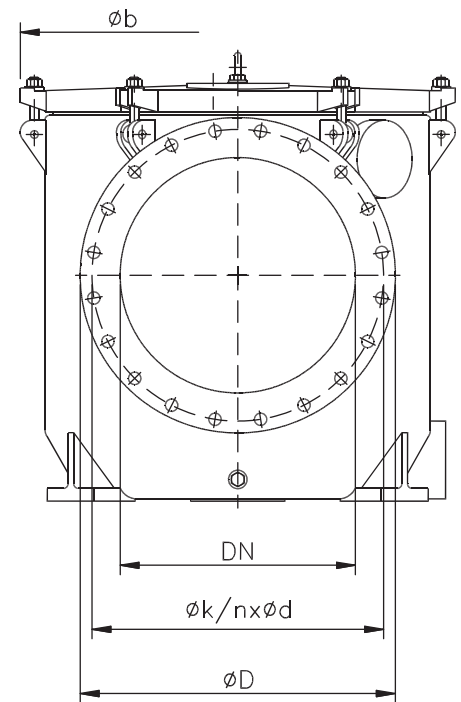
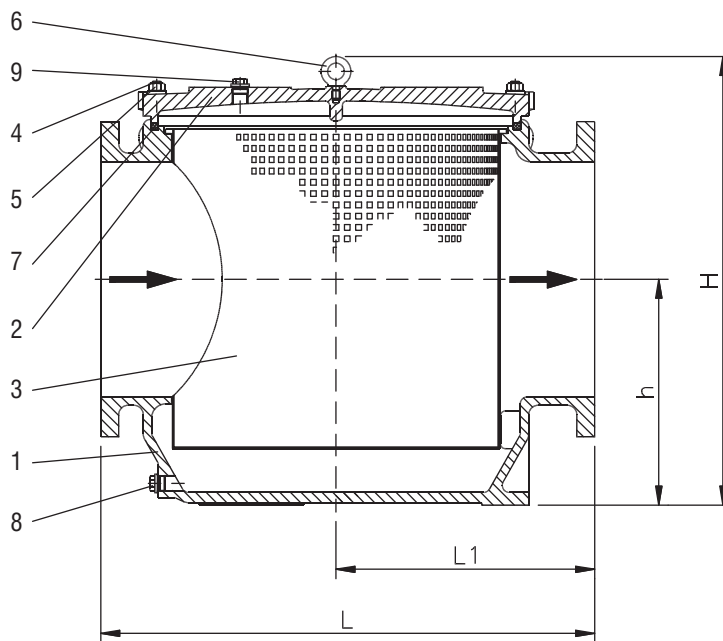

Abb. / figure: DN 500

Pos. / item	Bezeichnung / denomination	AW 608.0		Pos. / item	Bezeichnung / denomination	AW 608.0	
1	Gehäuse / body	EN-GJS-400-15	EN-JS1030	7	Dichtung / gasket	NBR	
2	Deckel / cover	EN-GJS-400-15	EN-JS1030	8	Entleerungsschraube / drain bolt	CuZn39Pb2	CW612N
3	Sieb / screen	X5CrNi18-10	1.4301	9	Entlüftungskugelhahn / vent ball valve (optional)	CuZn39Pb2 galv.	CW612N
4	Augenschraube / eye bolt	5.8					
5	Mutter / nut	CuZn39Pb2	CW612N				
6	Ringschraube / ring bolt	C15E	1.1141				

DN	PN	L	L <sub>1</sub>	h	H	Øb	ØD	Øk	n	Ød	Normalleistung m <sup>3</sup> /h* normal capacity m <sup>3</sup> /h*	≈kg
200	2,5	600	300	335	580	558	340	295	8	22	170,0	151,0
250	2,5	600	300	345	620	500	395	350	12	22	265,0	175,0
300	2,5	600	300	335	620	500	445	400	12	22	380,0	181,0
350	2,5	690	345	380	700	615	505	460	16	22	520,0	235,0
400	2,5	910	455	425	800	735	565	515	16	26	650,0	485,0
500	2,5	1.050	550	475	1.000	930	670	620	20	26	1.050,0	740,0
600	2,5	1.100	600	525	1.150	930	780	725	20	30	1.500,0	830,0

\*:1,5 m/s